

TBSCX3 Charger Series

CX3 series “doubly safe” CC/CV lithium ion/polymer charger system

Description

The CX3 is pre-programmed at TBS to configure the model number required, see Table 1.

The CX3 charger will be provided with a plugged mains lead and a pluggable pack interface lead with flying tails identified B+ (red) and B- (black) and Th(where required).

Fig.1 CX3



Fig 2:Block schematic

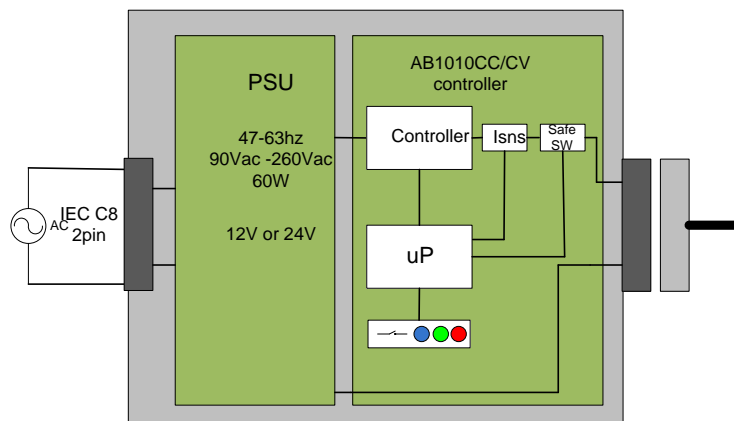

Referring to the block schematic , Fig.2. The DC power source for the charge controller is a 60W capable unit which has international safety and EMC qualifications. The CX3 charger is released to CE certification. Bespoke case is ABS to UL fire retardant specification.

The charge controller, AB1010, is designed by TBS specifically for the CX3 charger series and is directly compatible with the TBSPP Power Pack series of standard battery packs . The CX3 will allow charging of any lithium ion pack with a suitably specified performance requirement, fitted to the CX3 model number. Model variants allow for a battery pack 10K NTC thermister. 1S to 4S lithium packs , at either 2A or 3A can be charged, charger selection by model number.

A microprocessor is integrated into the charge controller and will drive the LEDs as well as having a switch off function on demand. It has “double safety “control inhibit on current and voltage independent of the charge controller.. These features cost money but TBS designers feel that the economic trade off versus safety has no contest.

Doubly safe –A TBS feature

Chargers can damage batteries! Even cause/contribute to an unsafe condition or reduced performance of the pack. If the charge controller fails (electrical and/or thermal stress failure is, not uncommon) the full power of the DC supply will be fed to the battery pack whose last line of defence is the voltage overcharge function lithium ion protector.[Some protectors have charge overcurrent protection as well as overcharge voltage protection] This in turn could damage the control Mosfets in the pack protector. If such a failure occurs the first symptom could be a charge current well in excess of the regulated constant current rate. The battery pack voltage clamping the charger will rise with battery charge until an unsafe point is reached at around 4.6V/cell, if the pack protector has failed. The microprocessor will immediately detect the excess current and inhibit charge immediately at the point in time of the failure, flashing failure LED. If output voltage as clamped by battery exceeds the model CV by 5% the charge will be inhibited and failure indicated

The input power requirement fits international AC single phase specifications with a maximum input power required of 75W.

Operation

When AC power is applied the PWR led illuminates, both charge and fail LEDs will be off. Charging will commence automatically on connection to the battery pack. The CX3 applies continuous short pulses designed to wake up a battery pack whose protector is off. When charging commences if the battery voltage is below a set level then the charge applied is fractional until the pack voltage rises to a point where fast charging can now safely commence. The charge LED will flash at an approximate rate of 0.3Hz. As the pack reaches about 90% full the rate will change to 1hz, on charge termination the charge LED [green]illuminates full on. The charger will then wait and if the pack voltage falls below a preset limit re-charging will commence.

Removing the pack at any point of the cycle will revert the charger to its waiting state, PWR LED remains on.

If the charger disable/enable switch is depressed at any time then charging is inhibited, so charge activation pulses be applied. In this mode the red FL will flash at 0.3hz, another press will release the inhibit and the RED led will be extinguished. Normal operation will resume

If an unsafe condition is detected then the charge is inhibited and the red LED full on, the charge Led is turned OFF. If it is a time out event then the Red led will flash at 1hz, charging terminated.

The algorithm applied by the charger is constant current (CC) followed by constant voltage (CV) then current taper termination at around 8% to 12% of the charge rate. Noting that charge rate, depending on chemistry should be equal or less than 0.7C, for example a 3AH cell should only be charged at a maximum rate of $3 \times 0.7 = 2.1A$. The charge CV for lithium ion NMC is usually 4.2V +/- 1%, CX3 chargers are preconfigured to this limit but can be configured to lower limits if required, say 4.1V, this lower limit extends battery life considerably but at a loss of capacity. Ensure the cell manufacturers limits are adhered to.

Time out safety is applied by the AB1010 charge controller AND the Microprocessor.

The charge controller AB1010 has an on board 10K thermister which disallows charge if too low or too high temperature. This is not related to pack temperature. However CX3 models with a "T" suffix are designed to accept an external 10K thermister for allowing pack temperature control of the charger. Ideally this external Themister would be located thermally to the cells in the pack . So if cells too hot or cold charging inhibited. The charger will not display LED advice if charging temporarily inhibited. Note: a model "T" will not charge unless it senses an external thermister and it needs to be in range.

Table 1. CX3 models

CX3 Models	CV	CC	Description
TBSCX3-3S2A	12.6V +/-1%	2A +/- 10%	3 series 2A Lithium Ion Charger
TBSCX3-3S3A	12.6V +/-1%	3A +/- 10%	3 Series 3A Lithium Ion Charger
TBSCX3-4S2A	16.8V +/-1%	2A +/- 10%	4 Series 2A Lithium Ion Charger
TBSCX3-4S3A	16.8V +/- 1%	3A +/- 10%	4 Series 3A Lithium Ion Charger

2. Specification

- Nominal dimensions in mm LWH 88/108/34 (52 to Apex)
- Mass approx. *gms
- Connectivity a) AC inlet 2 pin IEC C8, b) output socket, push pull “Lemo style”
- Connectivity a) CX3-A connector assembly to interface TBSP power pack & CX3-B connector assembly with flying leads for customer termination to pack
- AC 47hz to 63hz, 90Vac to 260Vac, 75W maximum
- Overall efficiency [PSU and charge controller combined] typically 75%
- CV , 4.2V, 8.4V,12.6V,16.8V all +/-1% for 1S,2S,3S,4S
- CC 2A or 3A +/-10%
- Current taper termination 0.2A or 0.3A +/- 10%
- Temperature control -5C to +50C +/-5C. note: on board 10K Th or external 10K Th (model needs specified for variant required)
- Approvals- CE release designed to meet safety and EMC regulations